

ADVANCED TECHNOLOGY Inc.

Fits: Mossberg 500*/590/835, Winchester 1200/1300, Remington 870

*NOTE: SYNTHETIC FORENDS ON NEW MOSSBERG MODEL 500A

CANNOT BE REPLACED BECAUSE ACTION BARS ARE ATTACHED TO THE FOREND.*

PISTOL GRIP BUTTSTOCK & FOREND PACKAGE

INSTALLATION INSTRUCTIONS

PART# PGB6100, PGB6100C

Thank you for purchasing one of Advanced Technology Inc.'s SHOTFORCE COMPONENTS!
Please fill out the enclosed Unconditional Lifetime Warranty card and mail it within 30 days of purchase.



MOSSBERG 500*/590/835, REMINGTON 870, WINCHESTER 1200/1300

MAKE SURE YOUR SHOTGUN IS UNLOADED BEFORE STARTING!

TO REPLACE BUTTSTOCK

- STEP 1** Remove the existing recoil pad from your shotgun stock by unscrewing the two (2) Phillips head screws in the rear of the pad.
- STEP 2** Use a long flat blade screwdriver to remove the stock bolt from the inside of the opening in the rear of the stock.
- STEP 3** Select the adapter for your shotgun. **The Mossberg & Maverick require no adapters.** Remington, Norinco & Winchester adapters are marked.

MODIFICATION FOR 20 GAUGE REMINGTON

ALL REMINGTON 20 GA

Alteration of adapter (SPG0130) is required.

- Alter SPG0130 adapter as shown below.
- Check fit-up of adapter to shotgun as shown below.

FOR OTHER SHOTGUN MODELS: NO ALTERATIONS ARE REQUIRED

SPG0130 Remington Adapter alteration (shown in white). Must be filed Approx 1/32 over entire projected surface of adapter and use dremel tool to remove interference with receiver post. File, and check against receiver for fit.

CHECK FOR CONTACT BETWEEN TRIGGER GUARD AND FRONT PISTOL GRIP FACE
(File Face if Required)

CHECK SAFETY RELEASE
(File if Pin Does Not Move)

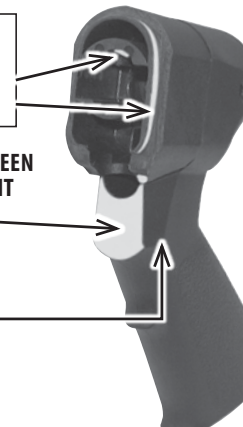

INSTALL AS SHOWN

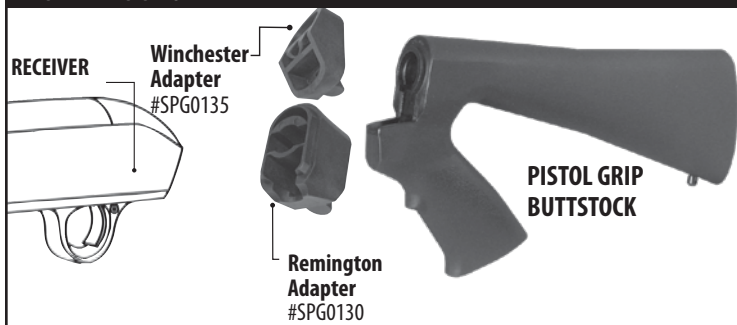

- STEP 4** Select the rear spacer. **ALL SHOTGUNS** will use platform #SPG0111. **Remington** has (2) different stock bolt lengths. If the stock bolt length is 10-1/8" long, use spacers SPG0114 and SPG0113 placed over stock bolt as shown. If stock bolt is less than 8" long, use SPG-0114 only.
- Winchester** does not require any spacers. **Mossberg and Maverick** will only use spacer SPG0112. **Norinco 98** will use spacer SPG0114 cut to 1-1/4" as shown.

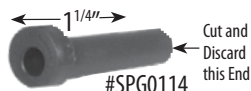

- STEP 5** Place the stock bolt through spacer(s) and platform and install in the rear of the stock. With the stock bolt extending out of the front of the stock, place the front adapter over the bolt and against the stock. Place the buttstock up to the rear of the receiver and secure by tightening the stock bolt.

- STEP 6** Place the new recoil pad on the rear of the stock and secure with the two (2) screws provided. **CAUTION: Do not overtighten any screws.**

REMINGTON (10-1/8" LONG SCREW)

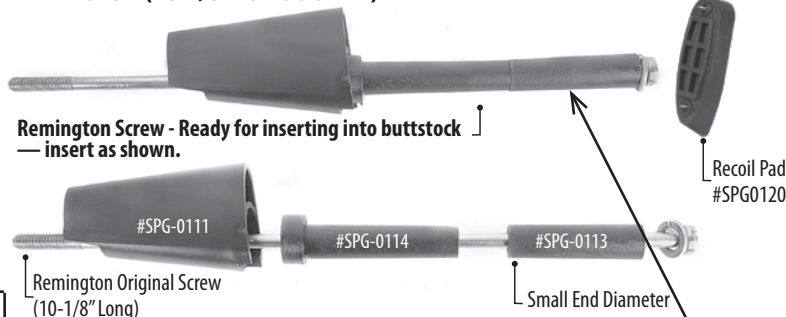

REMINGTON (8" LONG SCREW)



WINCHESTER



MOSSBERG/MAVERICK



NORINCO



FOR EACH MODEL: ALL PARTS MUST BE PUSHED TOGETHER BEFORE INSERTING INTO PISTOL GRIP BUTTSTOCK.

Advanced Technology, Inc. • Made in USA • Lifetime Warranty • No Gunsmithing

www.ATGunstocks.com • 102 Fieldview Dr. • Versailles, KY 40383 • PH: 859-873-9877 • FAX: 859-873-6229



ADVANCED TECHNOLOGY Inc.

Fits: Mossberg 500*/590/835, Winchester 1200/1300, Remington 870

PISTOL GRIP BUTTSTOCK & FOREND PACKAGE

INSTALLATION INSTRUCTIONS
PART# PGB6100, PGB6100C

NOTE: SYNTHETIC FORENDS ON NEW MOSSBERG MODEL 500A CANNOT BE REPLACED BECAUSE ACTION BARS ARE ATTACHED TO THE FOREND.

STANDARD FOREND LAYOUT FOR PARTS ASSEMBLY (FIGURE #1)

(Remove Plastic Bridge)

FRONT ADAPTERS

Part Numbers Marked Inside Adapters
Mossberg 500 Long = MF1
Mossberg 500 Short = MF2
Remington 870 = RF (Norinco)
Winchester 1200/1300 = WF

(Remove Plastic Bridge)

REAR ADAPTERS

Part Numbers Marked Inside Adapters
Mossberg 500/590/835 = MR
Remington 870 = RR (Norinco)
Winchester 1200/1300 = WR

- Remove ring nut from front of tube.
- Remove old forend by pulling it forward off the tube.
- Select front and rear adapters for your shotgun.
- Assemble as shown.
- Place ring nut on forend tube and tighten.

MODIFICATION FOR 20GA MOSSBERG MODELS 500/590/835

FRONT ADAPTER
PART# MF-2

FOR 20 GAUGE MOSSBERG ONLY
Increase surface and diameter shown in white until Ring Nut fits freely (1/32 larger)

- Use DREMEL tool on low setting with grinding attachment. (CAUTION: HIGH RPM will generate excessive heat and damage adapter).

MODIFICATIONS FOR REMINGTON 20 GAUGE

Alter "Tee" Wrench To Remove Remington Standard Forend

- Use hacksaw or grinder to remove metal.

Purchase 'O-Ring' Or Flat Washer For Remington 870 Standard And Pistol Grip Forends To Improve Tightening Capability (O-Ring/Washer Not Included)

Shotshell Holder
\$14⁹⁹ MSRP

Top Folding Stock with Rear Pistol Grip
\$69⁹⁹ MSRP

Pistol Grip Buttstock
\$44⁹⁹ MSRP

Expandable Ammo Carrier
\$15⁹⁹ MSRP

Deluxe Heatshield with Ghost Ring Sights
\$28⁴⁹ MSRP

Rear Pistol Grip
\$20⁹⁹ MSRP

Moss/Rem/Win ShotForce Tactical Stock with Free ButtPad
\$69⁹⁹ MSRP

Heatshield \$24⁹⁹ MSRP
Marine Finish Heatshield w/Ghost Ring Sights \$34⁹⁹ MSRP

Forend Pistol Grip
\$24⁹⁹ MSRP

H&R/NEF
Transform your original 12-16-20 Gauge and .410 H&R or NEF Single Shot Shotguns with SHOTFORCE! No Gunsmithing! Simply shorten barrel (minimum 18 1/2"), remove old wood, then re-install SHOTFORCE components.

Expandable Ammo Carrier
\$15⁹⁹ MSRP

Featherweight Bipod
\$34⁹⁹ MSRP

Tactical Buttpad
\$12⁹⁹ MSRP

H&R Tactical Stock with Forend
\$69⁹⁹ MSRP

Deluxe Heatshield with Ghost Ring Sights
\$28⁴⁹ MSRP

Muzzle Mount
\$15⁹⁹ MSRP

Tactical Shotgun Holder
\$15⁹⁹ MSRP

FOREND ASSEMBLY INSTRUCTIONS

Step 1 Cycle action once to make sure hammer is cocked and engage safety.

Step 2 Depress slide release and pull forend approximately halfway back, loosen magazine cap and remove barrel.

Step 3 (Mossberg) Remove trigger group retaining pin by tapping it out with a blunt pin no greater than 3/16" in diameter.

(Winchester) Remove trigger group retaining pin by tapping it out with a blunt pin no greater than 1/4" in diameter.

(Remington and Norinco) Depress and hold left shell stop (see figure #2).

Step 4 (Mossberg) Place shotgun upside down and pull out trigger group by lifting up at the rear. (see figure #5)

(Winchester) Place shotgun upside down and remove retainer and trigger group pin. (see figure #8)

Step 5 (Mossberg) Remove shell stop and shell interrupter from receiver.

(Winchester) Turn shotgun back upright and pull forend forward and off magazine tube. Remove bolt from action bars.

(Remington) Slide forend forward off magazine tube. NOTE: The bolt and slide block will also be removed (see figure #3).

Step 6 (Mossberg) Align bolt slide with cut out in receiver by moving forend and action bars back and forth. Remove bolt slide upward (figure #7). Pull forend and action bars forward & remove from magazine tube.

Step 7 (All Models) Assemble forend as shown in figure #1.

Step 8 (Mossberg) To reassemble, slide forend back on magazine tube and align action bars with the openings in the receiver.

(Remington) Slide forend back on magazine tube and replace bolt and slide block. (see Figure #3) Place action bars into receiver and pull rearward until it stops.

(Winchester) Place forend back on magazine tube and replace bolt in the action bar slots (See figure #9).

Step 9 (Mossberg) Align the slots on the action bars with the slots on the bolt slide and replace bolt slide (figure #7).

(Remington) Press right shell stop (figure #4). The forend with the bolt will slide further rearward and stop again. Press the left shell stop (see figure #2) and the forend will travel fully to the rear.

(Winchester) Align action bars with openings in the receiver and pull the forend rearward.

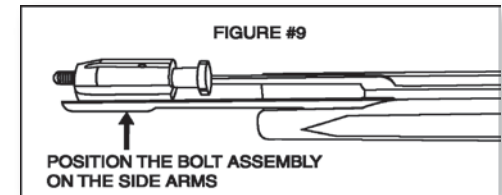
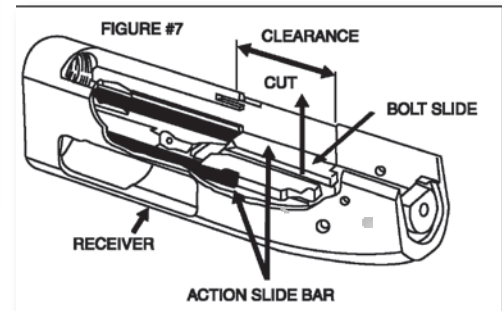
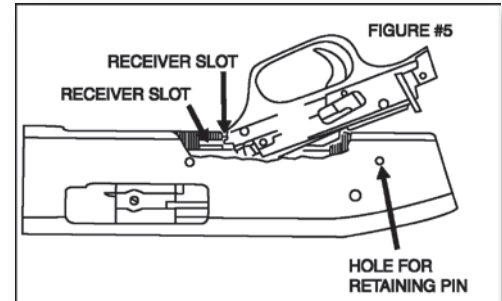
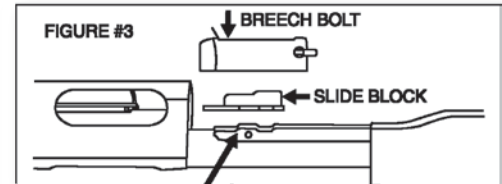
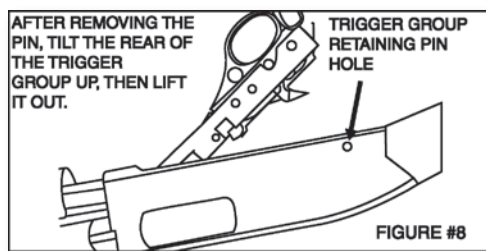
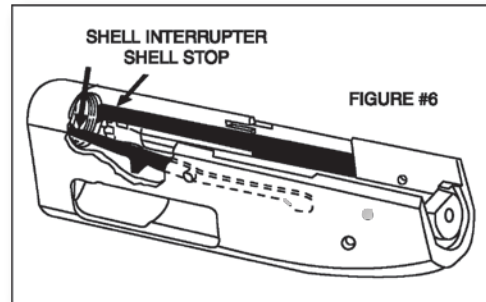
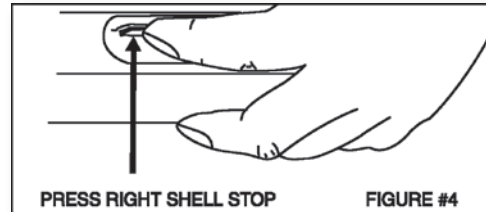
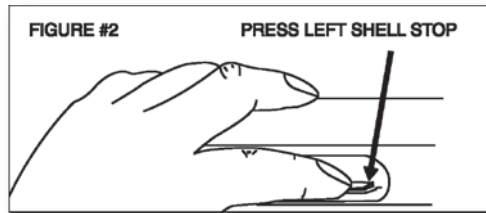

Step 10 (Mossberg) Replace both the shell interrupter and shell stop (figure #6).

(Remington) Slide the forend forward approximately half way and replace barrel and magazine cap.

Step 11 (Mossberg) Replace trigger group and pin (see figure #5).

(Winchester) Turn shotgun upside down and replace trigger group and retain pin (see figure #8).

NOTE: SYNTHETIC FORENDS ON NEW MOSSBERG MODEL 500A CANNOT BE REPLACED BECAUSE ACTION BARS ARE ATTACHED TO THE FOREND.

